



KULI base 基础模块介绍

Christian Rathberger
Department Energy & Fluid Simulation
Engineering Center Steyr GmbH & Co KG,
4300 St. Valentin, AUSTRIA



What is **KULI** base?
什么是**KULI** base?

KULI modules



KULI hvac

A/C and Heat Pump
System Development
空调及热泵系统开发



KULI base

All your Basic Needs for
Steady State Cooling System Design
基础稳态冷却系统设计

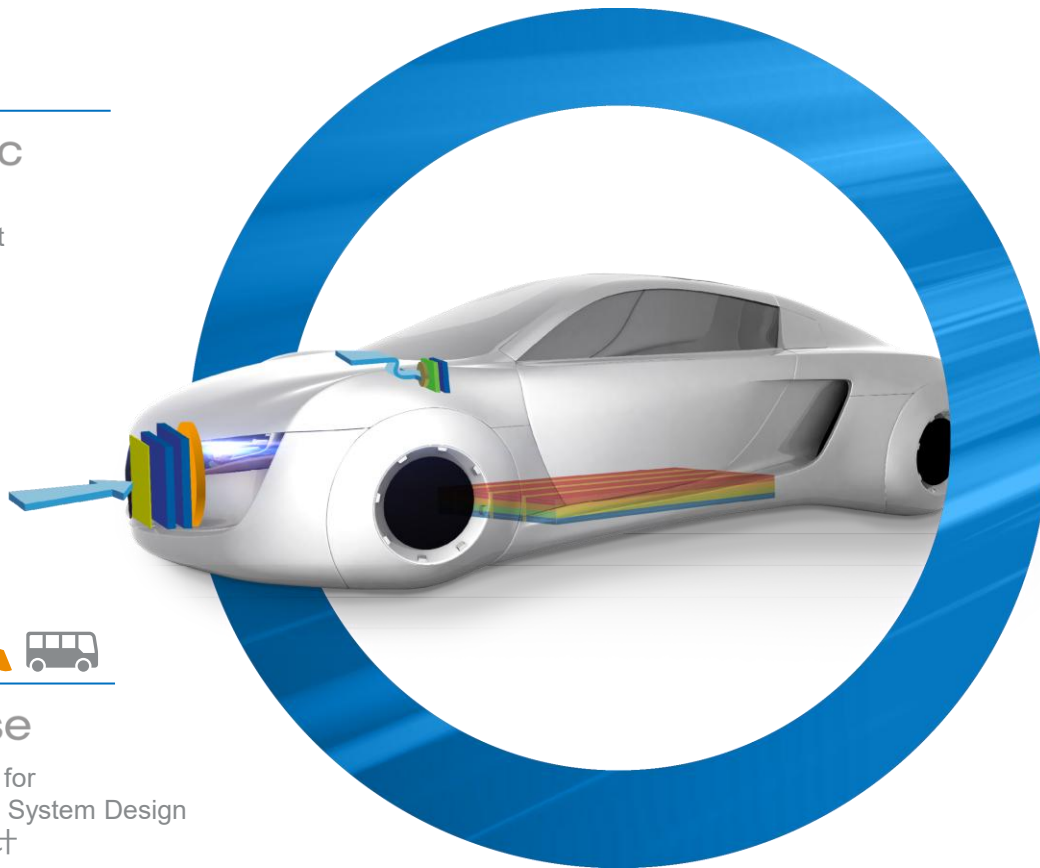

KULI drive

Drive Cycles and Engine Model
驾驶循环及发动机模型



KULI eco

EV Battery to Powertrain
动力电池



KULI advanced

Interfaces, CFD and Optimization
接口、CFD及优化

Thermal and energy management software 热管理以及能量管理软件

Understand All VTM

System Key Properties:

用于理解所有热系统关键属性

- Temperatures 温度
- Pressure Levels 压力
- Mass Flow Distribution 流量
- Heat- & Energy Flows 热量及能量
- Passenger Comfort 乘员舱舒适性
- Control Strategies 控制逻辑

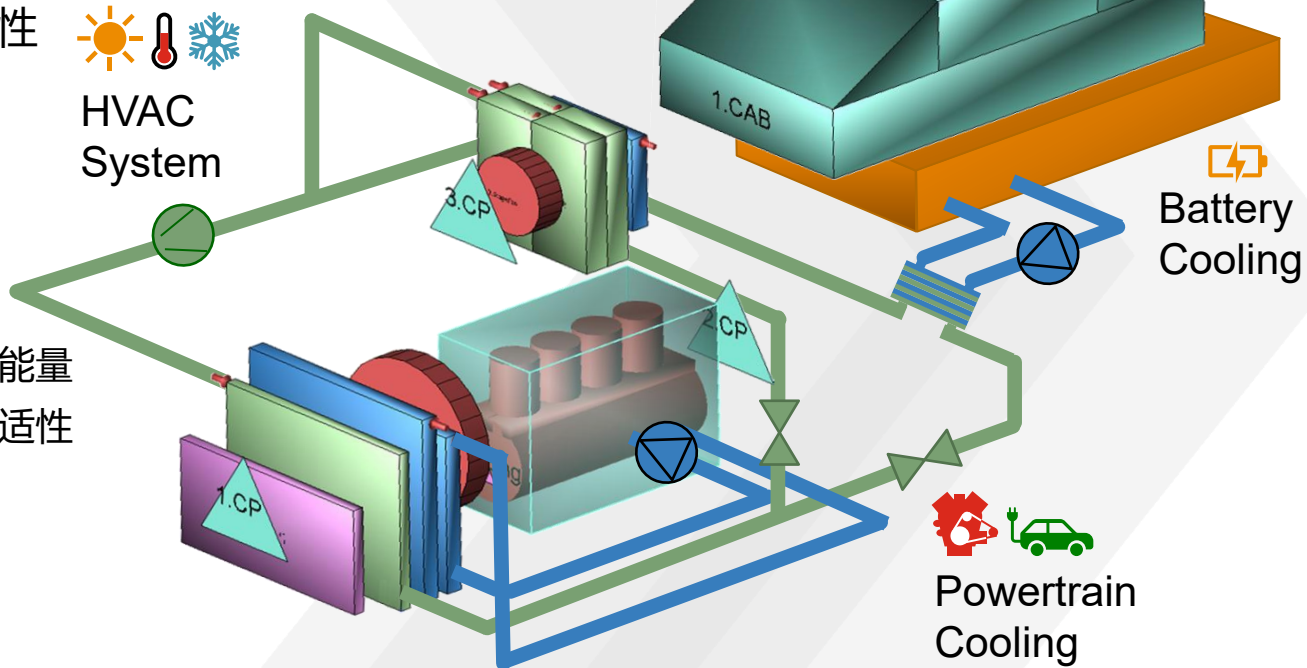

Components & Features

零部件及特性

KULI base – engine cooling scheme 发动机冷却布置

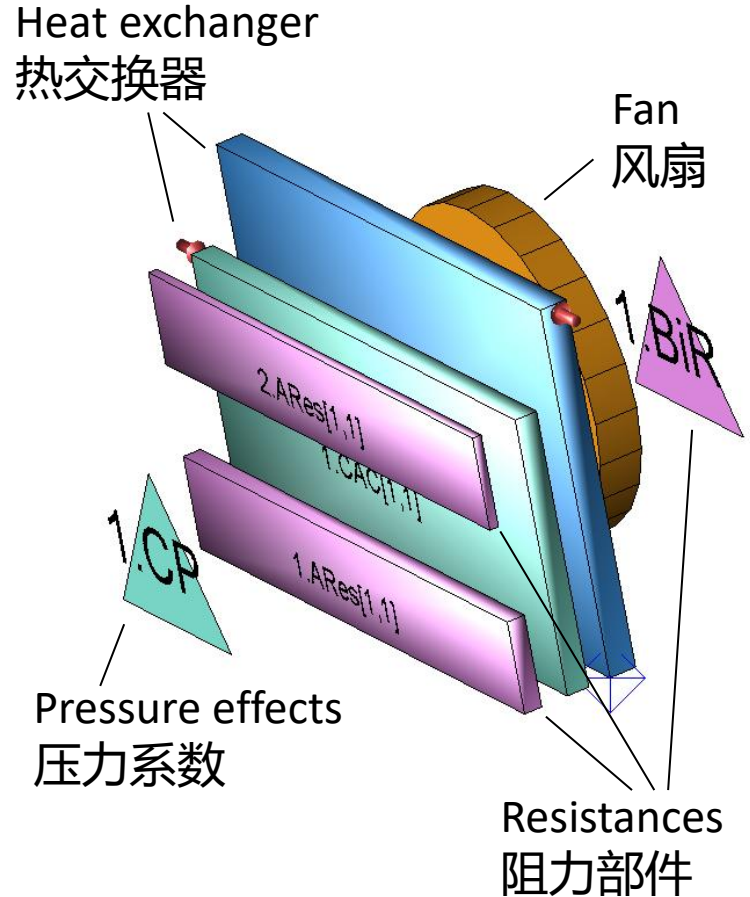
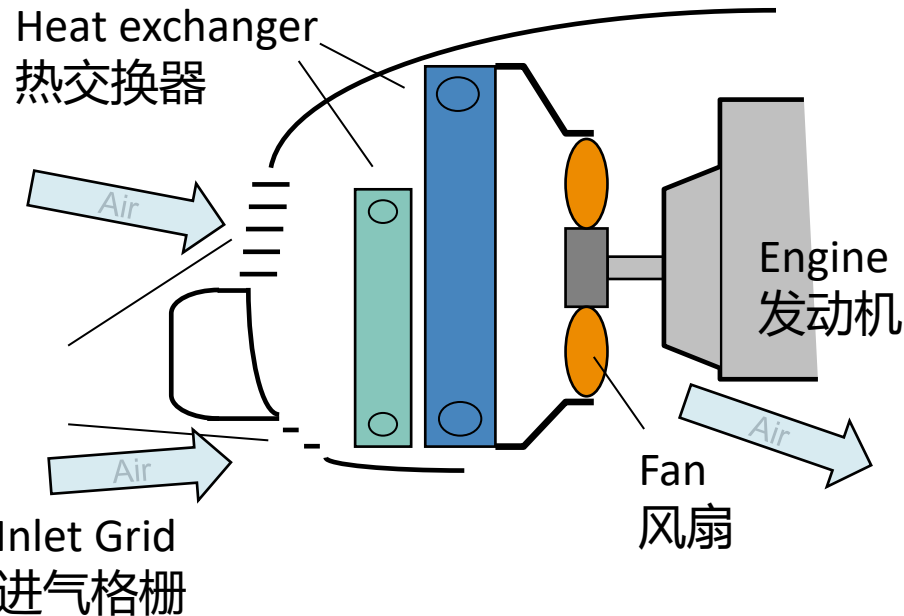

KULI base – Heat exchanger data input

热交换器输入数据



Heat exchanger components

热交换器

characteristic data 特性数据



Radiator [ExCAR.kuliRad]

File Tool Extras

General data Inner flow Outer flow Heat transfer User Shape

User: TZS
Date (0=current): 28.05.1996 00:00:00
Title: ExampleCAR
Memo:

Type: Cross-flow
No.: NC001
Manufacturer: WK
Series: CL001
Measrd. data file: MF001

Geometric data
Width [mm]: 600
Height [mm]: 400
Depth [mm]: 30

Layout
 Standard
 U-flow
 S-flow Passes: 1

Tube data
Overall tube number: 46
No of rows of tubes: 1
Tube cross-section [mm²]: 40
Wetted perimeter [mm]: 22.42

Flow properties inner side
 mixed unmixed

Extended thermal properties

Geometric data

几何数据

WxHxD, Tube data
宽度x高度x厚度, 管路数据

Pressure loss

压力损失

Inner side, outer side
热侧, 冷侧

Heat transfer map

换热曲面

KULI base – fan data input 风扇输入数据



Fan component

风扇

characteristic data

特性数据

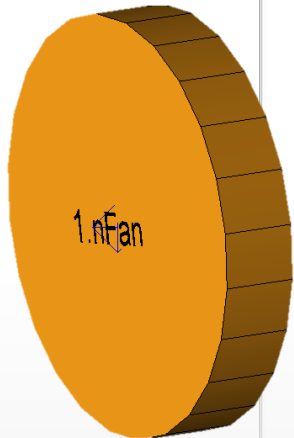

Speed-controlled fan [ExCAR.kuliRPMfan]

Simulation parameters

Ambient medium: Air

Entry temp. of cooling air [°C]: 20

Entry press. of cooling air [hPa]: 1000

Relative humidity [%]: 0

Unit of flow rate: kg/s

Unit of press. difference: N/m²

Unit of power: kW

RPM: 3100

Flowrate	Pressure difference	Power	RPM (informative)
0.4	500	1	3100
0.5	485	1.1	3100
0.6	470	1.2	3100
0.7	450	1.25	3100
0.8	400	1.3	3100
0.9	328	1.4	3100
1.03	189	1.45	3100
1.3	0	1.47	3100

Geometric data
几何数据

Diameter, hub depth
直径, 风轂厚度

Characteristics
特性曲线

Pressure rise, power cons.
静压、功耗

Control strategy
控制逻辑

RPM or stage
转速 或者 档位

1.nFan

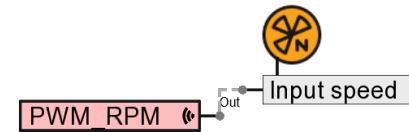

KULI base – air resistance data input 空气侧阻力输入数据



Air resistance

空气侧阻力

dimensionless or non-dimensionless

无量纲或者非无量纲



Built-in Resistance

内置阻力

Pressure loss due to engine comp.

发动机舱压力损失

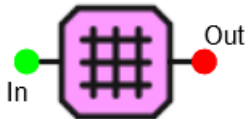

Area resistance

区域阻力

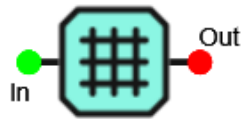

Inlet grid

进气格栅

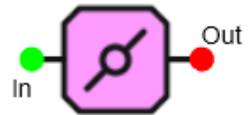

Air flap

风门



$$\Delta p = a \cdot \text{Flow}^2 + b \cdot |\text{Flow}|^c$$

$$\Delta p = \zeta \cdot \frac{\rho}{2} \cdot \vec{v}^2$$

Characteristics

特性参数

Measurement 测试

Parameter

公式参数

Often 通常 $b=c=0$

Pressure loss

压力损失系数

“Zeta”-value

KULI base – Fluid Side Components

液侧零部件

Resistances 阻力部件

1.RAD [I] 1.PFC [I] 1.PHE [I]

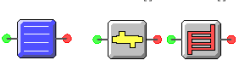

Heat Exchangers 热交换器

1.BND 1.RES 1.TUB 1.FLUIDFLAP

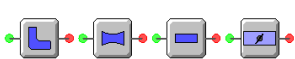

Tubes, Resistances, Bends
管路、管阻、弯管

1.BRA 1.CONF 1.VALVE



Branches, Confluences, Valves
分支、汇流、阀门

1.PU



Pump 水泵

1.SC 1.ETC [I] 1.ETC [O]

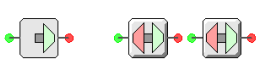

Supercharger, Exhaust-Gas-Turbocharger
机械增压、废气涡轮增压

Abstract Sources 抽象目标

1.MFL 1.PRESS 1.TEMP 1.LAMBDA

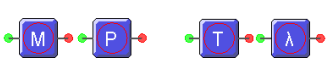

Targets: Mass- / Heat Flow, Pressure, Temperature, Lambda
目标对象：质量-/热量流量、压力、温度

KULI base – component overlap 零部件重疊

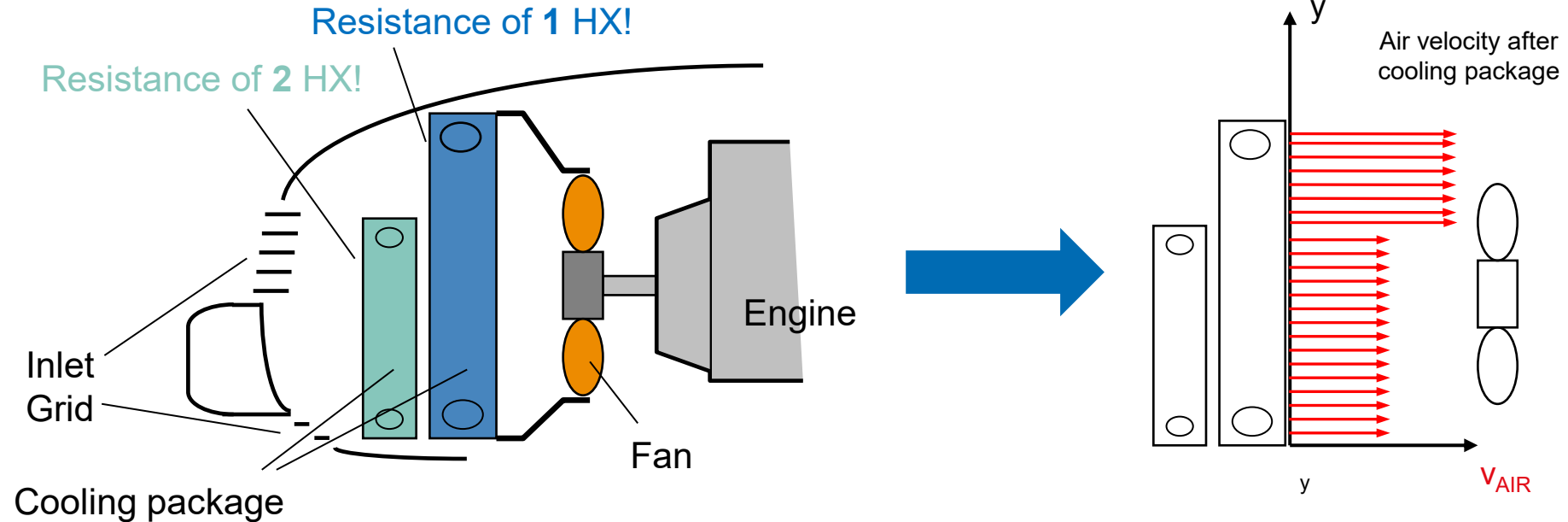

Non-Uniform Flow Distribution

KULI base – component overlap 零部件重疊

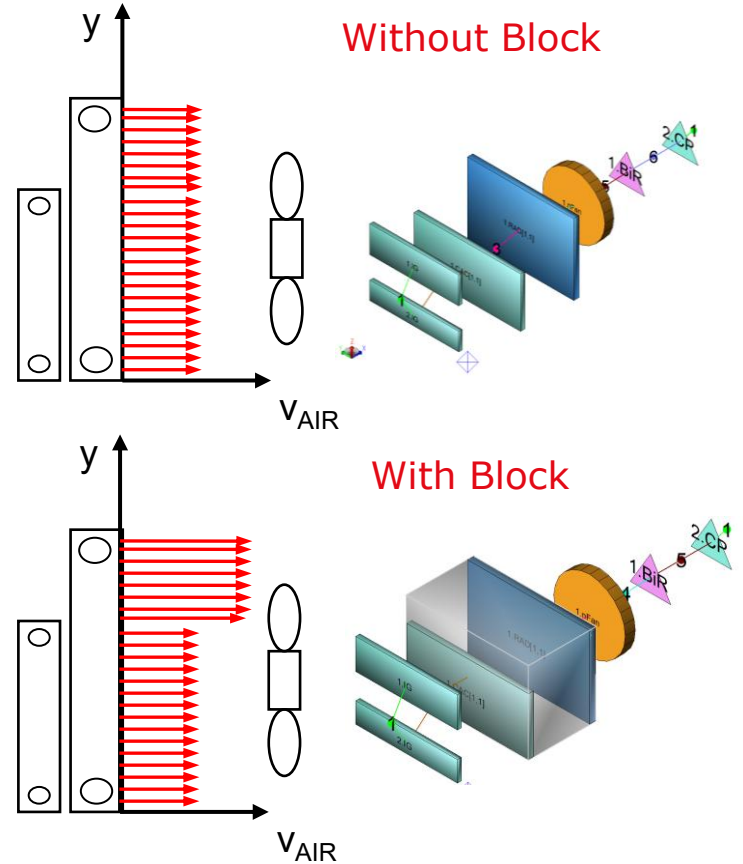
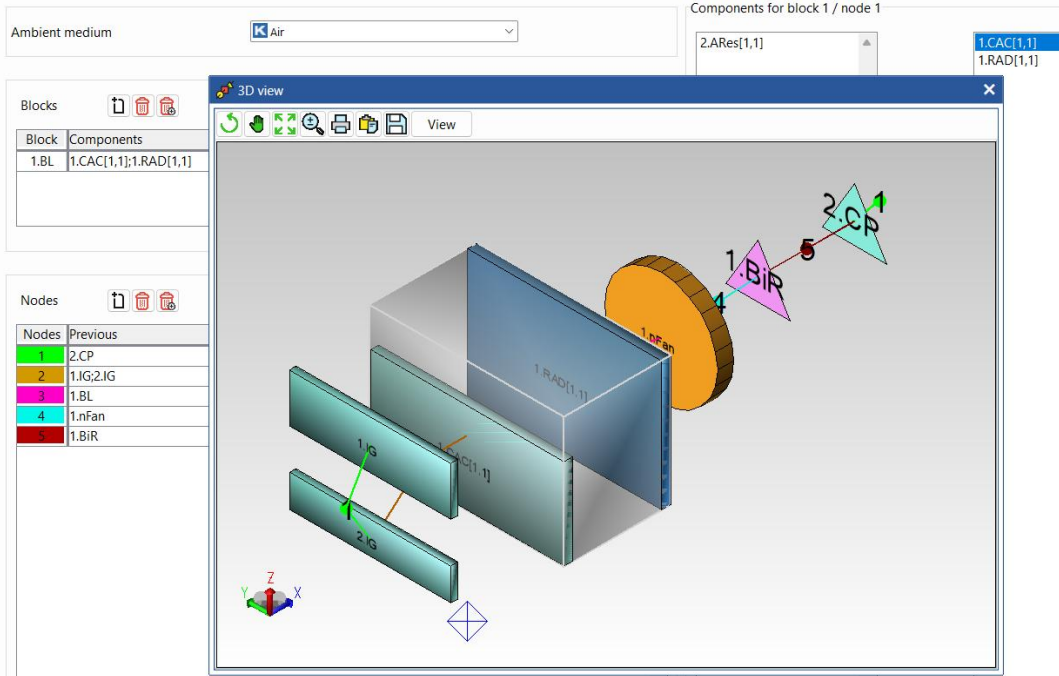

KULI base – component overlap 零部件重疊

“Block”-Definition vs. “Node”-Definition

“Node”-Definition

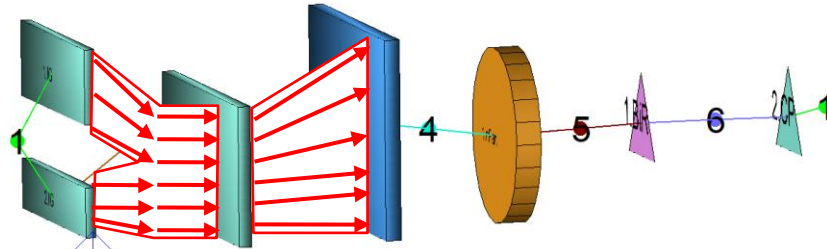

“Block”-Definition

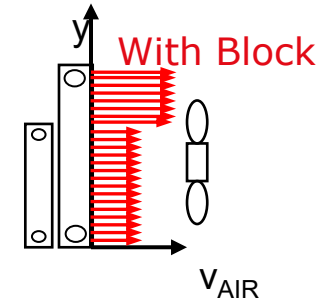
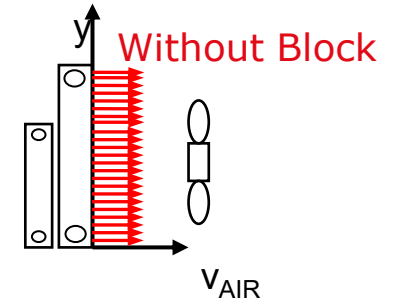
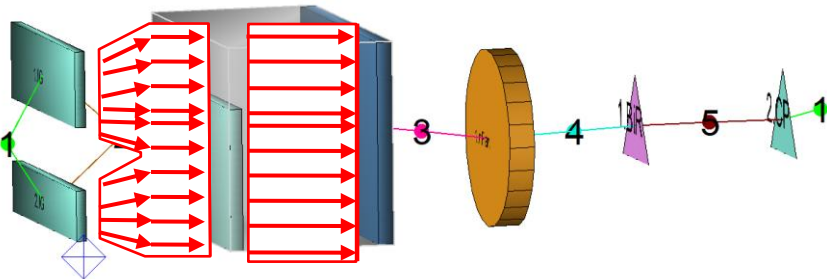

KULI base – circuits 循环回路

Basic scheme
布置方案

2D View in KULI
KULI中的二维视图

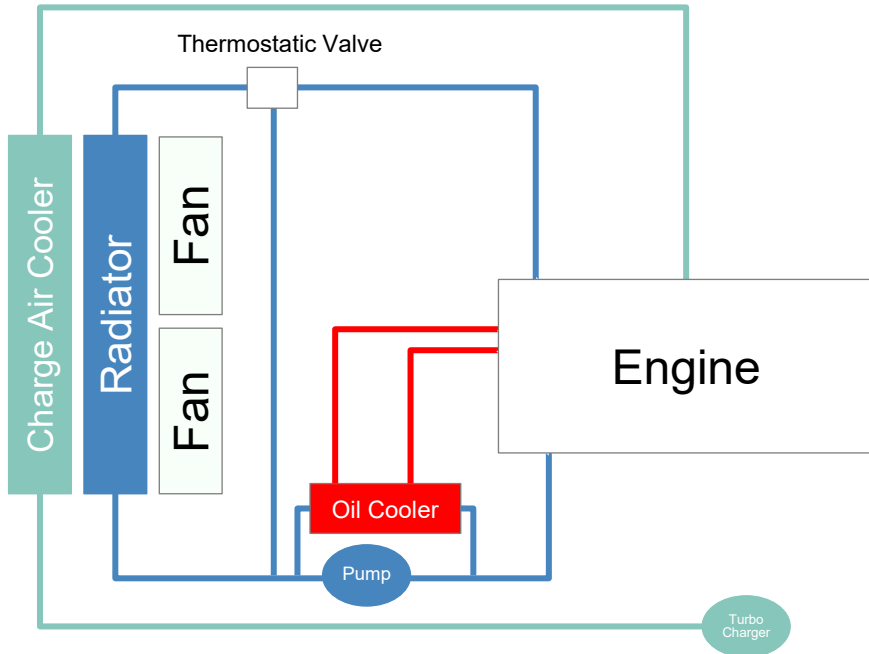

Hydraulic circuit
液侧回路

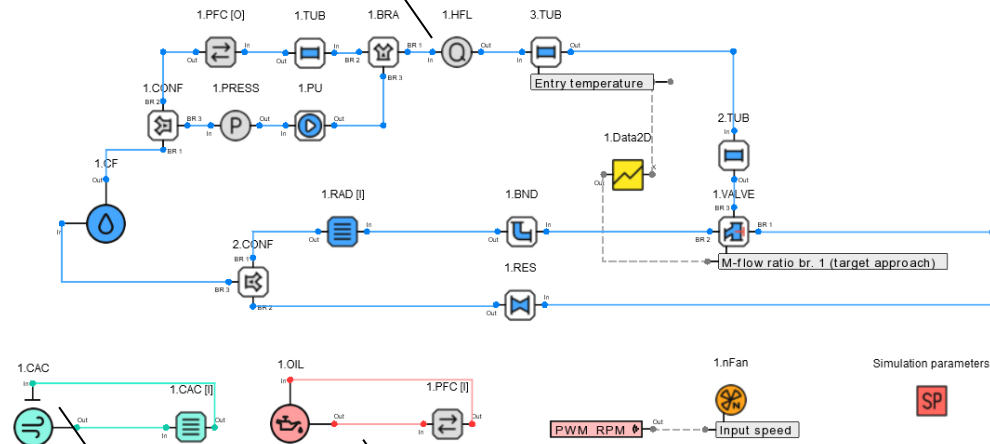

Open circuit
开循环

Closed circuit
闭循环

KULI base – fluid components

液侧零部件

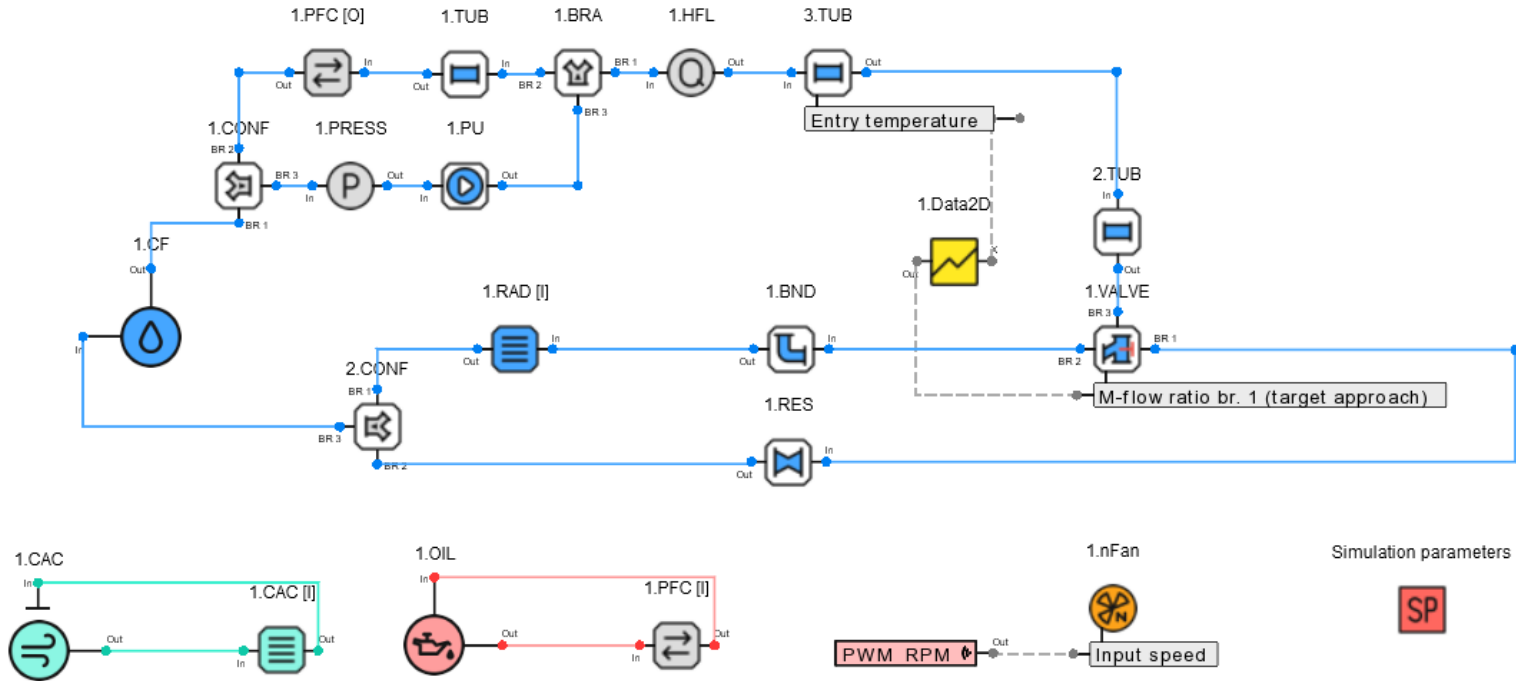

KULI base – fluid circuits 液侧回路

Closed circuit 闭循环

Purpose: Find temperature levels in circuit

目的：计算循环回路温度

Requirements: Engine heat to be removed

需求：输入发动机散热量

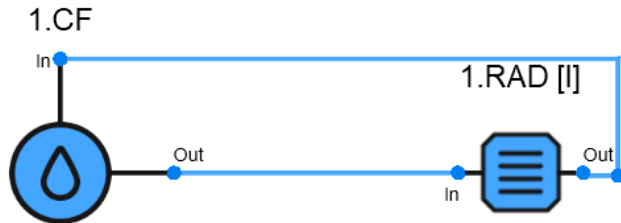

Open circuit 开循环

Purpose: calculate heat transfer rate

目的：计算换热量

Requirements: entry temp. of heat exchanger

需求：输入换热器入口温度

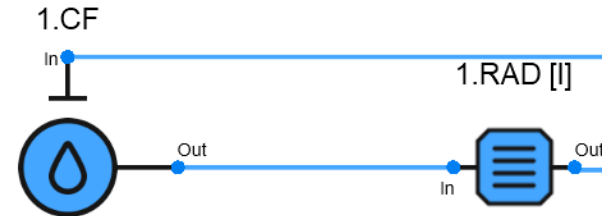

	Closed	Open
Input	Q	T
Output	T	Q

KULI base – fluid circuits 冷却回路



Mass flow approach 设置流量大小

Purpose: cooling module performance

目的：计算冷却模块性能

Requirements: flow rate through relevant branches

需求：设置相关支路的流量大小

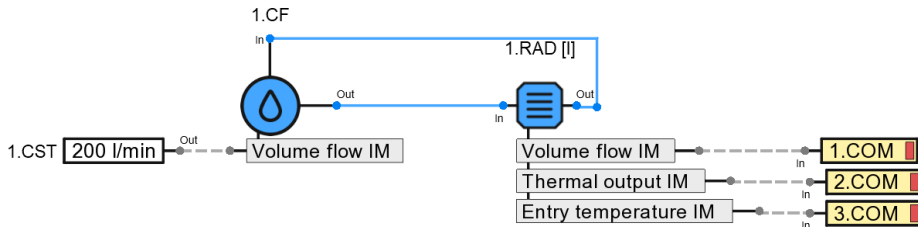

Resistance approach 设置阻力大小

Purpose: mass flow + detailed coolant flow

目的：计算质量流量及冷却液流量分布

Requirements: piping structure (resistance)

需求：设置管路结构（相关阻力）

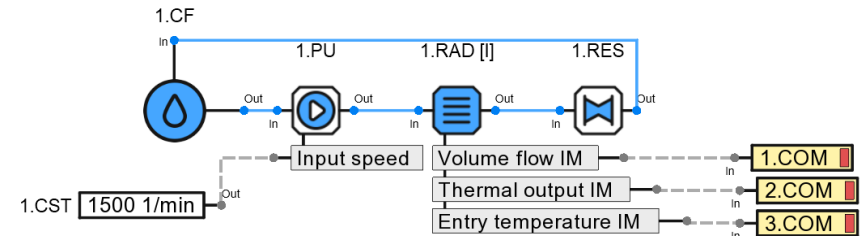

KULI base – actuators and sensors 执行器与传感器

Simulation parameters

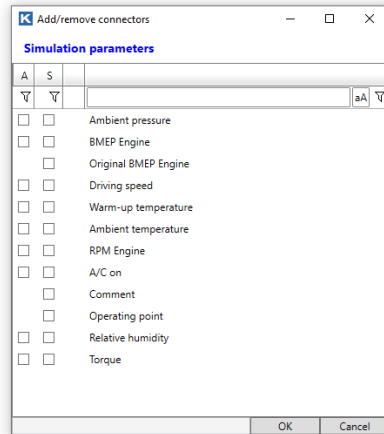

Simulation parameters

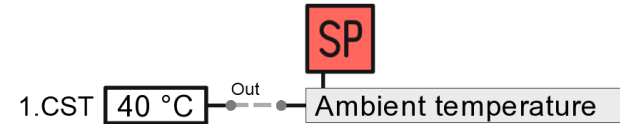

KULI base – actuators and sensors

执行器与传感器

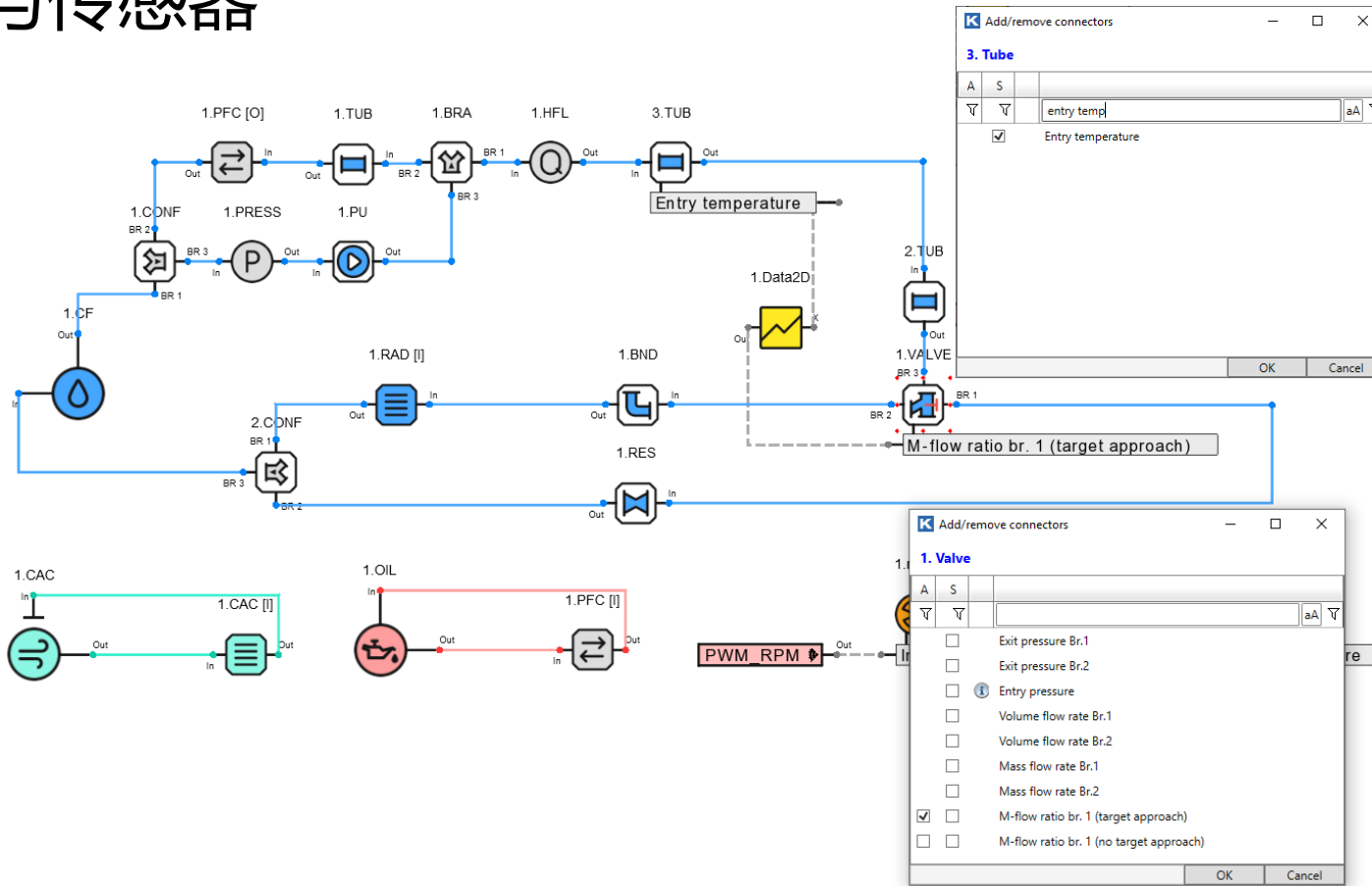

KULI base – system check

系统检查

- KULI provides the possibility to check a given system for modelling errors and other possible pitfalls that could affect the quality of the simulation result,
KULI 提供了检查给定系统中是否存在建模错误及其他可能影响仿真结果质量的潜在问题的功能
- If you save or run a file, then a subset of the full System check, called Error check, is automatically performed. This Error check verifies that the model does not contain modelling mistakes that would prevent it from being simulated at all.
当您保存或运行文件时，系统会自动执行完整系统检查的一个子集，称为错误检查。该错误检查用于验证模型中是否包含会完全阻碍其仿真的建模错误。
- All the problems that are discovered by the System check are collected in the System report panel.
系统检查发现的所有问题都会汇总在系统报告面板中。

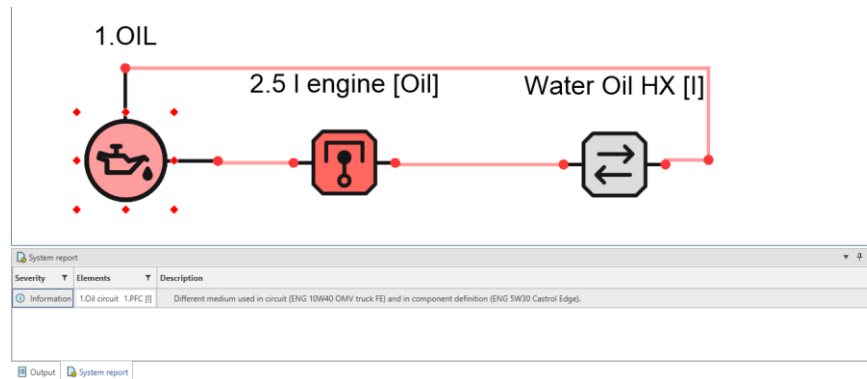

KULI base – Search Function

搜索功能

- There is a search field in the toolbar of KULI for direct access to the online resources
在 KULI 的工具栏中有一个搜索栏，可直接访问在线资源：
 - KULI manual
KULI 手册
 - KULI online library
KULI 在线数据库
 - KULI knowledge base
KULI 知识库
- A quick overview of the search results is given
搜索结果会提供一个快速概览
- A link to the online resource is provided
并附有指向在线资源的链接

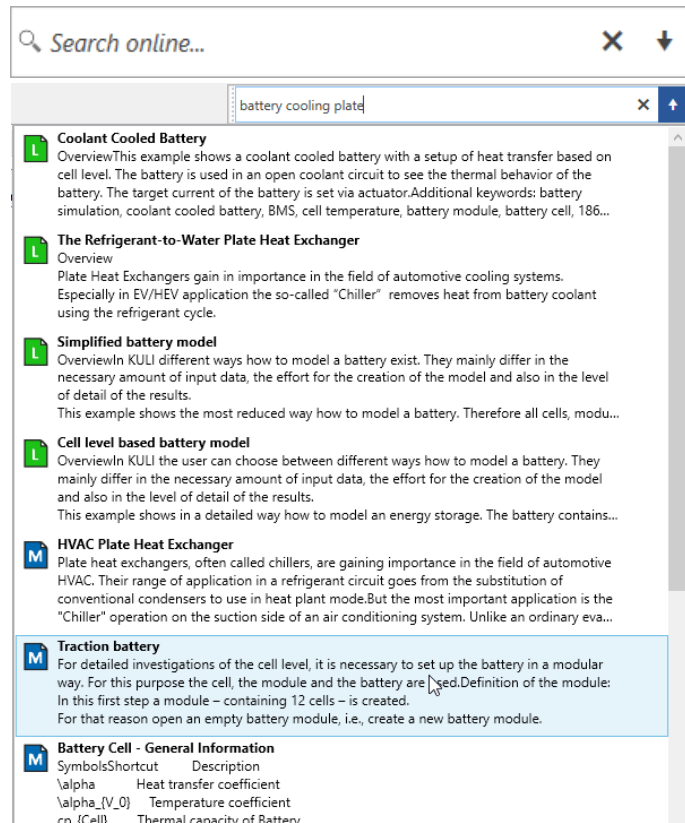

Search online... X ↓

battery cooling plate X ↑

- Coolant Cooled Battery**
Overview This example shows a coolant cooled battery with a setup of heat transfer based on cell level. The battery is used in an open coolant circuit to see the thermal behavior of the battery. The target current of the battery is set via actuator. Additional keywords: battery simulation, coolant cooled battery, BMS, cell temperature, battery module, battery cell, 186...
- The Refrigerant-to-Water Plate Heat Exchanger**
Overview
Plate Heat Exchangers gain in importance in the field of automotive cooling systems. Especially in EV/HEV application the so-called "Chiller" removes heat from battery coolant using the refrigerant cycle.
- Simplified battery model**
Overview In KULI different ways how to model a battery exist. They mainly differ in the necessary amount of input data, the effort for the creation of the model and also in the level of detail of the results.
This example shows the most reduced way how to model a battery. Therefore all cells, modu...
- Cell level based battery model**
Overview In KULI the user can choose between different ways how to model a battery. They mainly differ in the necessary amount of input data, the effort for the creation of the model and also in the level of detail of the results.
This example shows in a detailed way how to model an energy storage. The battery contains...
- HVAC Plate Heat Exchanger**
Plate heat exchangers, often called chillers, are gaining importance in the field of automotive HVAC. Their range of application in a refrigerant circuit goes from the substitution of conventional condensers to use in heat plant mode. But the most important application is the "Chiller" operation on the suction side of an air conditioning system. Unlike an ordinary eva...
- Traction battery**
For detailed investigations of the cell level, it is necessary to set up the battery in a modular way. For this purpose the cell, the module and the battery are used. Definition of the module: In this first step a module – containing 12 cells – is created.
For that reason open an empty battery module, i.e., create a new battery module.
- Battery Cell - General Information**
Symbols Shortcut Description
\\alpha Heat transfer coefficient
\\alpha_{V_0} Temperature coefficient
c_{(Cell)} Thermal capacity of Battery



Forward. For all.